

Hydraulic Installation Guidelines

Appendix A

Keyway Guidelines

When using keys and keyways to mount a clutch/brake, clutch, or brake on a shaft, the dimensions of the keyways and keys should be made in accordance with an accepted standard. Currently the most common standards are the ANSI B17.1 which is used for inch series shafts, and the DIN 6885 for millimeter series shafts. Either of these standards may be used for inch or millimeter shafts by a simple conversion of units (inch to mm or mm to inch). The DIN 6885 generally gives a more compact rectangular key/keyway combination.

In either standard, a tight side to side fit between the key and the hub and shaft keyways is required. In the ANSI B17.1 this is a class 3 fit. For tolerances on key and keyway widths Orttech recommends the following:

- Keyways per ANSI B17.1 be +0 / -.002 inch (+0 / -.05 mm) and keyways per DIN 6885 be to the P9 tolerance range.
- Keys per ANSI B17.1 be +.002 / -0 inch (+.05 / -0 mm) and keys per DIN 6885 be +.05 / -0 mm (+.002 / -0 inch)

This will require that the keys be fitted to the keyways at assembly. A loose fit key will result on a poor connection will allow the hub to move slightly on the shaft, which will cause wear and premature failure. A tight side to side fit will prevent this movement and provide a good connection.

For the hydraulic clutch/brakes, clutches, and brakes the rectangular keys are recommended, particularly for the larger bores, as they are more compact than square keys and allow the maximum bore to be used.

When designing a keyed connection, the strength of the key and that of the hub and shaft materials must be considered. The shear strength of the key(s) must be sufficient to transmit the torque. Also, the bearing stresses in the faces of the key and keyways that contact each other must not exceed the allowable limits for the materials. For the material used in the hub of the *Ortlinghaus* hydraulic clutch/brakes, clutches, and brakes a reasonable maximum bearing stress is 21,755 psi (15,000 N/cm²). To calculate the shear stress in the key, the formula $S = (T/R) / (w * l)$ can be used. To calculate the bearing stress in a keyway the formula $B = (T/R) / (b * l)$ can be used. S is shear stress in psi, B is bearing stress in psi, T is torque to be transmitted in lb-in, R is shaft radius in inches, w is width of key in inches, l is length of key in contact with keyway in the hub, and b is the height of the keyway in contact with the key.

If two keys are used, which is recommended in most cases (180° apart), allowances must be made for the keys having an unequal load distribution due to machining and fitting variances. Tapered keys and keys with a tight top and bottom fit are not recommended.

See Figure A1 and Table A1 for hub keyway limits. See Table A2 for shaft diameter/key combinations per ANSI B17.1. See Tables A3 and A4 for shaft diameter/key combinations per DIN 6885 Part 1.

If you have any questions please contact Orttech or your local Orttech representative.

Table A1
Hub Keyway Depth and Width Limits

C/B Size	Max. Bore (D)		Max. (T) in Hub Bore		Max. Key Width (W)	
	mm	inches	mm	inches	mm	inches
63	75	2.95	79.9	3.15	20	0.79
75	95	3.74	100.4	3.95	25	0.98
80	130	5.12	137.4	5.41	32	1.26
86	160	6.30	169.4	6.67	40	1.57
90	200	7.87	210.4	8.28	45	1.77
94	250	9.84	262.4	10.34	56	2.20
96	310	12.20	324.4	12.77	70	2.76
98	375	14.76	390.4	15.37	80	3.15

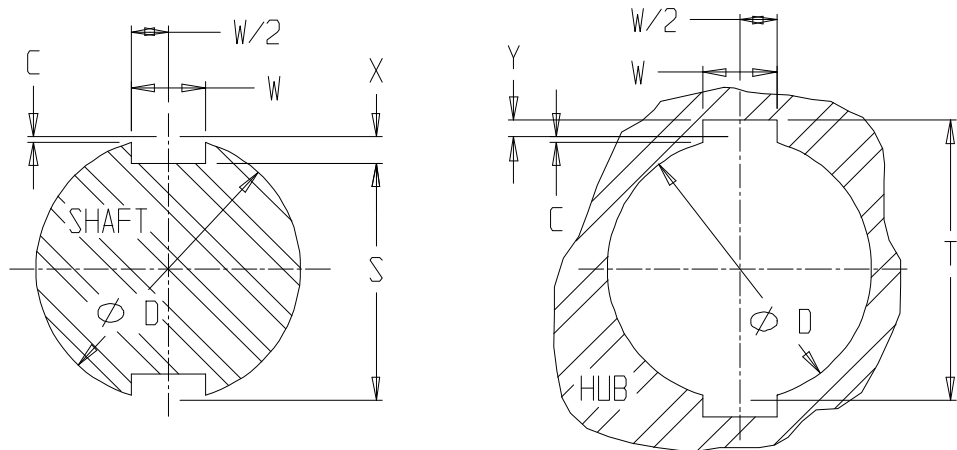

C – Chordal Height
 D – Nominal Diameter
 S – Dim.to bottom of Shaft Keyway

T – Dim.to top of Hub keyway
 W – Nominal width of keyway
 X – Depth of Shaft Keyway
 Y – Depth of Hub Keyway

Figure A1

Table A2
Shaft Diameter / Key Combinations Per ANSI B17.1

Dimensions in inches

Nom. Shaft Dia.		Rectangular Key	Square Key
over	to	(width x height)	(width & height)
5/16	7/16	---	3/32
7/16	9/16	1/8 x 3/32	1/8
9/16	7/8	3/16 x 1/8	3/16
7/8	1-1/4	1/4 x 3/16	1/4
1-1/4	1-3/8	5/16 x 1/4	5/16
1-3/8	1-3/4	3/8 x 1/4	3/8
1-3/4	2-1/4	1/2 x 3/8	1/2
2-1/4	2-3/4	5/8 x 7/16	5/8
2-3/4	3-1/4	3/4 x 1/2	3/4
3-1/4	3-3/4	7/8 x 5/8	7/8
3-3/4	4-1/2	1 x 3/4	1
4-1/2	5-1/2	1-1/4 x 7/8	1-1/4
5-1/2	6-1/2	1-1/2 x 1	1-1/2
6-1/2	7-1/2	1-3/4 x 1-1/2	1-3/4
7-1/2	9	2 x 1-1/2	2
9	11	2-1/2 x 1-3/4	2-1/2
11	13	3 x 2	3
13	15	3-1/2 x 2-1/2	3-1/2
15	18	4 x 3	4

Please Note:

1. For depth of keyways in the hub and shaft refer to “Depth Control Formulas” or Table 3 in the ANSI B17.1 Standard.
2. A minimum headroom clearance of .005 inch is recommended.
3. Recommended tolerance on keyway width is +0 / -.002 inch.
4. Recommended tolerance on key width is +.002 / -0 inch.
5. A tight side to side fit is required between the keys and the shaft and hub keyways. Hand fitting at assembly is usually required.
6. Key sizes listed in this table are per the ANSI B17.1 standard, maximum allowable key size for the hub is per Table A1.

Table A3
Shaft Diameter / Key Combinations per DIN 6885 Part 1

Nom. Shaft dia.				Key Width mm	Key Height mm	" X " For Shaft mm	" Y " For Hub mm
mm		inches					
over	to	over	to				
6	8	0.24	0.31	2	2	1.1 / 1.3	1.0 / 1.1
8	10	0.31	0.39	3	3	1.8 / 1.9	1.4 / 1.5
10	12	0.39	0.47	4	4	2.5 / 2.6	1.8 / 1.9
12	17	0.47	0.67	5	5	3.0 / 3.1	2.3 / 2.4
17	22	0.67	0.87	6	6	3.5 / 3.6	2.8 / 2.9
22	30	0.87	1.18	8	7	4.0 / 4.2	3.3 / 3.5
30	38	1.18	1.50	10	8	5.0 / 5.2	3.3 / 3.5
38	44	1.50	1.73	12	8	5.0 / 5.2	3.3 / 3.5
44	50	1.73	1.97	14	9	5.5 / 5.7	3.8 / 4.0
50	58	1.97	2.28	16	10	6.0 / 6.2	4.3 / 4.5
58	65	2.28	2.56	18	11	7.0 / 7.2	4.4 / 4.6
65	75	2.56	2.95	20	12	7.5 / 7.7	4.9 / 5.1
75	85	2.95	3.35	22	14	9.0 / 9.2	5.4 / 5.6
85	95	3.35	3.74	25	14	9.0 / 9.2	5.4 / 5.6
95	110	3.74	4.33	28	16	10.0 / 10.2	6.4 / 6.6
110	130	4.33	5.12	32	18	11.0 / 11.2	7.4 / 7.6
130	150	5.12	5.91	36	20	12.0 / 12.3	8.4 / 8.7
150	170	5.91	6.69	40	22	13.0 / 13.3	9.4 / 9.7
170	200	6.69	7.87	45	25	15.0 / 15.3	10.4 / 10.7
200	230	7.87	9.06	50	28	17.0 / 17.3	11.4 / 11.7
230	260	9.06	10.24	56	32	20.0 / 20.3	12.4 / 12.7
260	290	10.24	11.42	63	32	20.0 / 20.3	12.4 / 12.7
290	330	11.42	12.99	70	36	22.0 / 22.3	14.4 / 14.7
330	380	12.99	14.96	80	40	25.0 / 25.3	15.4 / 15.7

Please Note:

1. See table A4 for recommended keyway widths.
2. Recommended tolerance on key width is +.05 / -0 mm (+.002 / - 0 inch).
3. Using the "X" and "Y" dimensions given will allow proper headroom clearance.
4. A tight side to side fit is required between the keys and the shaft and hub keyways.
Hand fitting at assembly is usually required.

Table A4
Recommended Widths of Keyways made to DIN 6885 Part 1
 Tolerance Class is P9

Nominal Width (mm)	Keyway Width Limits	
	mm	inches
2	1.994 / 1.969	0.0785 / 0.0775
3	2.994 / 2.969	0.1179 / 0.1169
4	3.988 / 3.958	0.1570 / 0.1558
5	4.988 / 4.958	0.1964 / 0.1952
6	5.988 / 5.958	0.2357 / 0.2345
8	7.985 / 7.949	0.3144 / 0.3130
10	9.985 / 9.949	0.3931 / 0.3917
12	11.982 / 11.939	0.4717 / 0.4701
14	13.982 / 13.939	0.5505 / 0.5489
16	15.982 / 15.939	0.6292 / 0.6276
18	17.982 / 17.939	0.7080 / 0.7064
20	19.978 / 19.926	0.7865 / 0.7845
22	21.978 / 21.926	0.8653 / 0.8633
25	24.978 / 24.926	0.9835 / 0.9815
28	27.978 / 27.926	1.1016 / 1.0996
32	31.974 / 31.912	1.2588 / 1.2563
36	35.974 / 35.912	1.4163 / 1.4138
40	39.974 / 39.912	1.5738 / 1.5713
45	44.974 / 44.912	1.7707 / 1.7682
50	49.974 / 49.912	1.9675 / 1.9650
56	55.968 / 55.894	2.2035 / 2.2006
63	62.968 / 62.894	2.4791 / 2.4761
70	69.968 / 69.894	2.7546 / 2.7517
80	79.968 / 79.894	3.1483 / 3.1454